



## GEA Filtration

### Membrane Filtration

#### Model C Membrane Filtration Pilot Plant

The Model C membrane filtration pilot plant is a flexible unit for testing ceramic membranes on low pressure MF and UF applications. Model C pilot plants can be configured to run higher pressure UF/NF applications as well as other tubular membranes (inorganic or polymeric).

The Model C pilot plant can be setup to test a variety of membrane pore sizes, operating parameters (pressure, transmembrane pressure, cross-flow rate, temperature, backpulsing, etc.), and feed channel diameters (3mm, 4mm, and 6mm) to achieve optimal performance.

The ceramic membranes are available in a range of pore sizes or molecular weight cutoffs (MWCO): MF/UF membranes from 5 micron to 0.02 micron; UF/NF membranes of 5,000 and 1,000 MWCO.

The pilot plant can be operated in: batch mode, semi-batch mode, or feed and bleed mode. The pilot plant design has a single stage recirculation loop.

The Model C membrane filtration pilot plant is skid mounted and will be delivered with all the components required for quick installation and easy operation, including an operating manual with data sheet templates.

#### Standard Features

- One, tubular ceramic membrane module
- 50 gallon feed tank
- Backpulse device
- Control loops (temperature and tank level)
- Feed and recirculation pumps
- Motor starters
- Permeate and concentrate flow indicators
- Heat exchanger
- Temperature and pressure gauges
- 316L stainless steel construction
- Skid mounted



#### Operating Conditions

- Membrane Area 3.6 to 6.7 m<sup>2</sup>
- Permeate Capacity 100-500 gallons/hour
- Pressure up to 100 psig
- Temperature up to 200° F

#### Optional Items

- UF/NF membrane modules
- 300 psig
- Pretreatment equipment
  - screens and depth filters
  - chemical feed systems

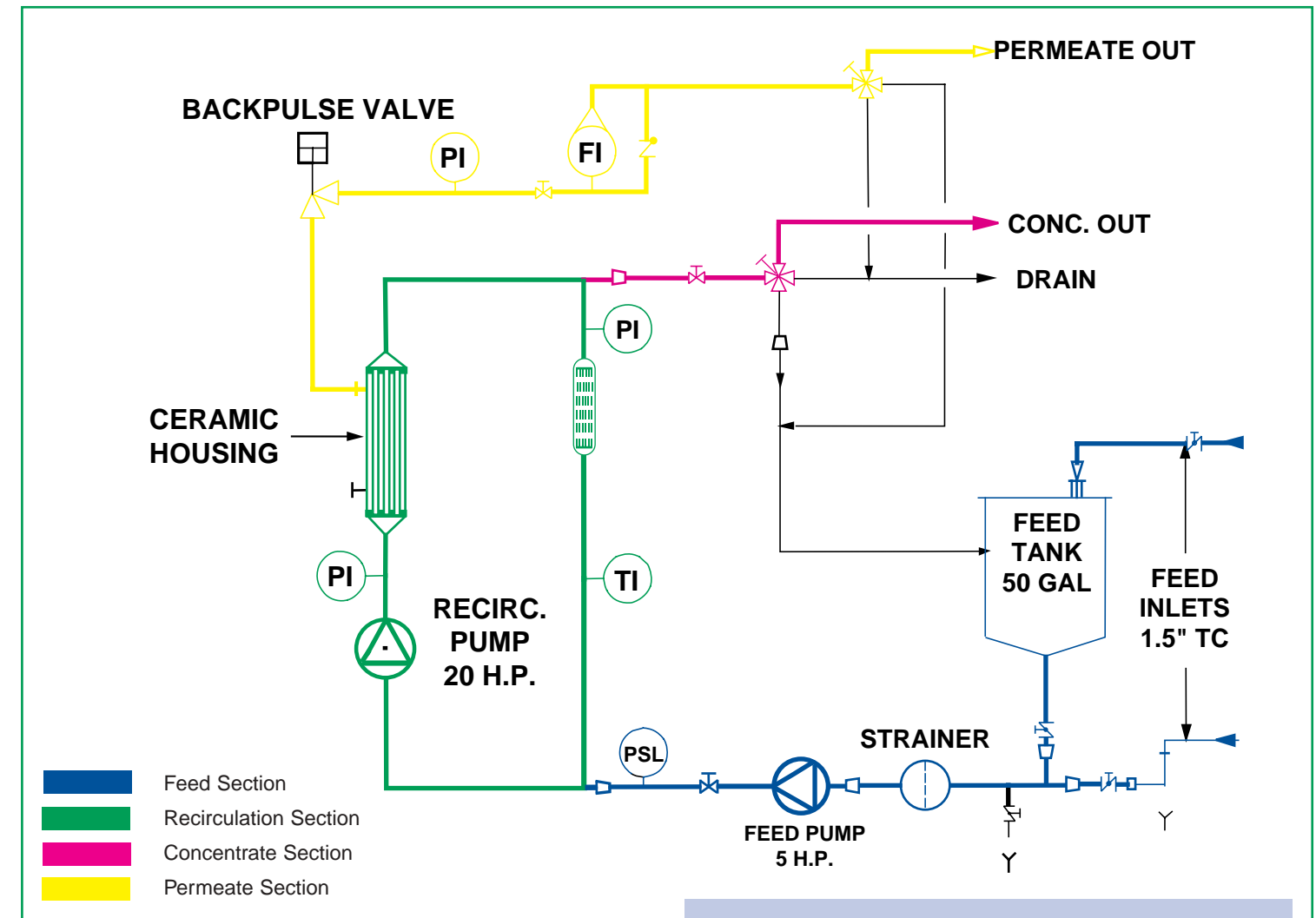

#### Utility Requirements

- Power 230/460 V, 3 phase, 60 Hz
- Electric Service 60 amps / 460 V
- Plant Air 80 psig, oil-free
- Plant Air Line 3/8"
- Cooling Water 15 gpm, 60° F
- CIP Water 25 gpm
- Seal Water 1 gpm

GEA Filtration is part of GEA, an international process engineering leader in the life sciences industry with more than 150 companies operating worldwide. As a team member with other technology leaders within the group, GEA Filtration is uniquely positioned to provide both customized membrane filtration plants as well as complete process lines specifically tailored to each customer's individual needs and requirements.

GEA Filtration is world renowned for its design of the most advanced cross-flow membrane filtration systems available, namely Reverse Osmosis (RO), Nanofiltration (NF), Ultrafiltration (UF) and Microfiltration (MF). We also offer a wide range of system configurations and membrane types to provide the customer with the most technically proficient and cost effective solution for each application.

For more information on the capabilities of our pilot plants, consult our website at [www.geafiltration.com](http://www.geafiltration.com).



GEA Filtration • Niro Inc. • 1600 O'Keefe Road • Hudson, Wisconsin 54016, USA • TEL 1 715 386 9371 • FAX 1 715 386 9376  
E-MAIL [info@geafiltration.com](mailto:info@geafiltration.com) • WEB [www.geafiltration.com](http://www.geafiltration.com)

GEA Filtration • GEA Liquid Processing Scandinavia A/S • Noerskovvej 1b • DK-8660 Skanderborg, Denmark  
TEL 45 70 15 22 00 • FAX 45 70 15 22 44 • E-MAIL [post@gea-liquid.dk](mailto:post@gea-liquid.dk) • WEB [www.gea-liquid.dk](http://www.gea-liquid.dk)